

WHITEHORSE CITY COUNCIL

VEHICLE CROSSING

TYPE 1 - RESIDENTIAL STREETS

(BARRIER KERB AND CHANNEL AND NATURE STRIP > OR = 3m)

AMENDED 08/23

S100A

CONCRETE THICKNESS
TAPERS FROM 150mm
TO 75mm.

W (3000 MINIMUM)

MINIMUM
600

TJ = TROWEL JOINT
SC = SAW CUT

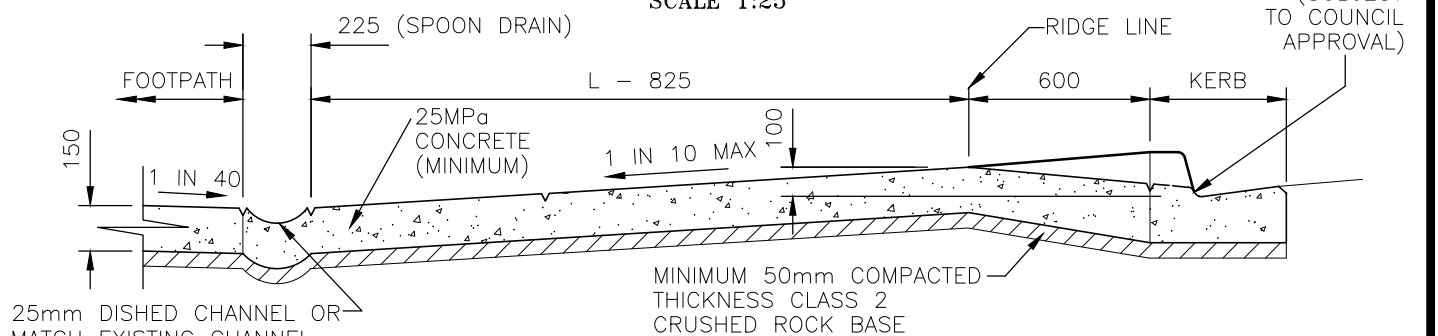
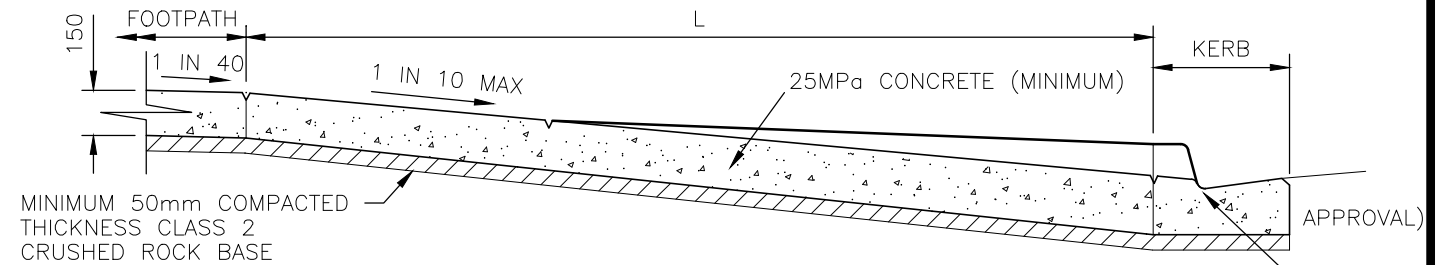
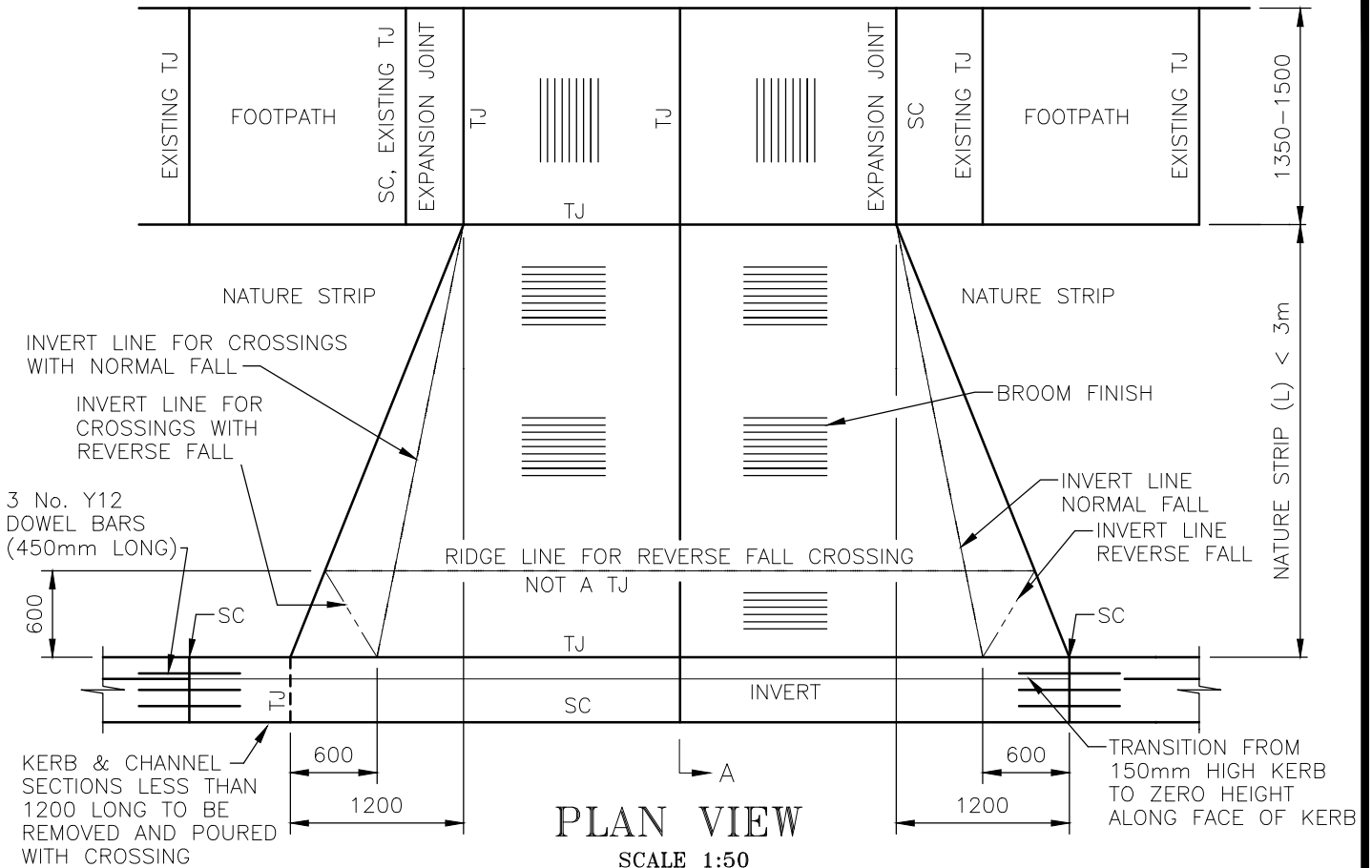

WHITEHORSE CITY COUNCIL

VEHICLE CROSSING

TYPE 1 - RESIDENTIAL STREETS

(BARRIER KERB AND CHANNEL AND NATURE STRIP < 3m)

AMENDED 08/23

S100B

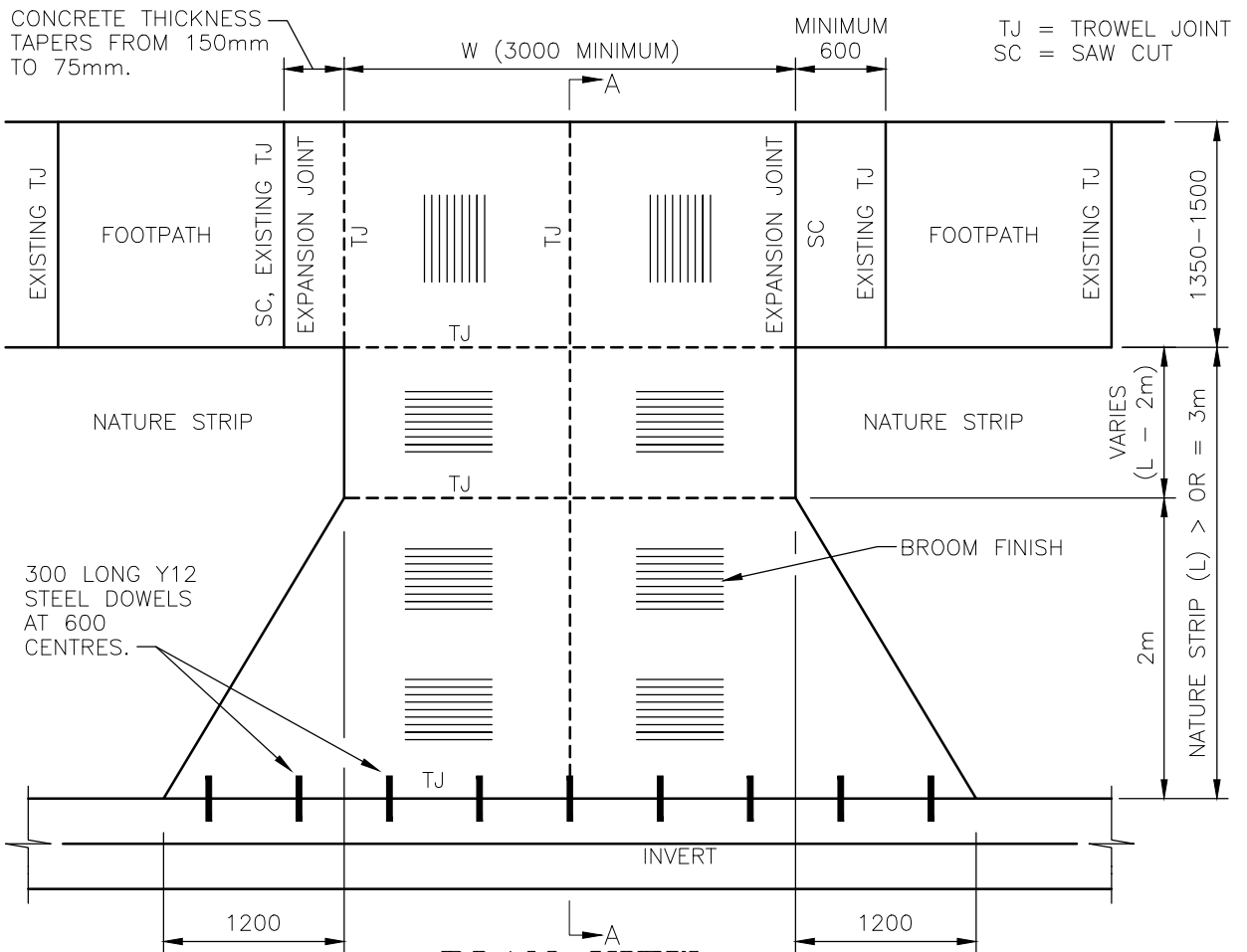

PLAN VIEW

SCALE 1:50

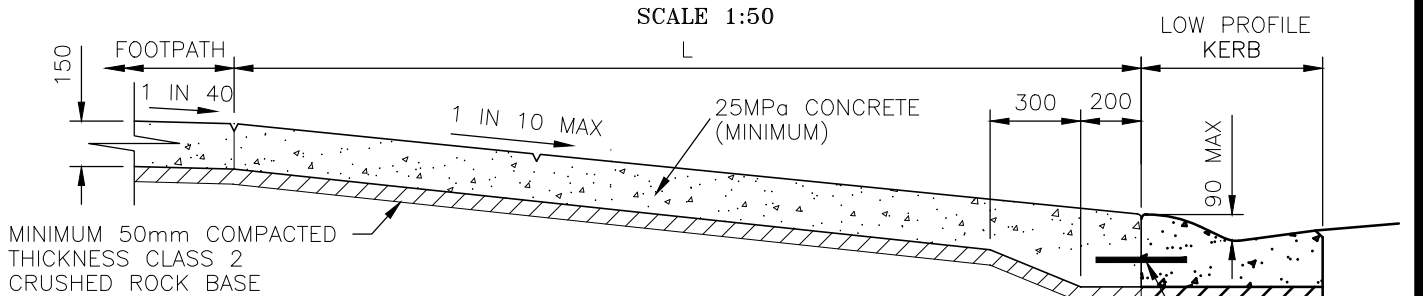

SECTION A-A NORMAL FALL CROSSING

SCALE 1:25

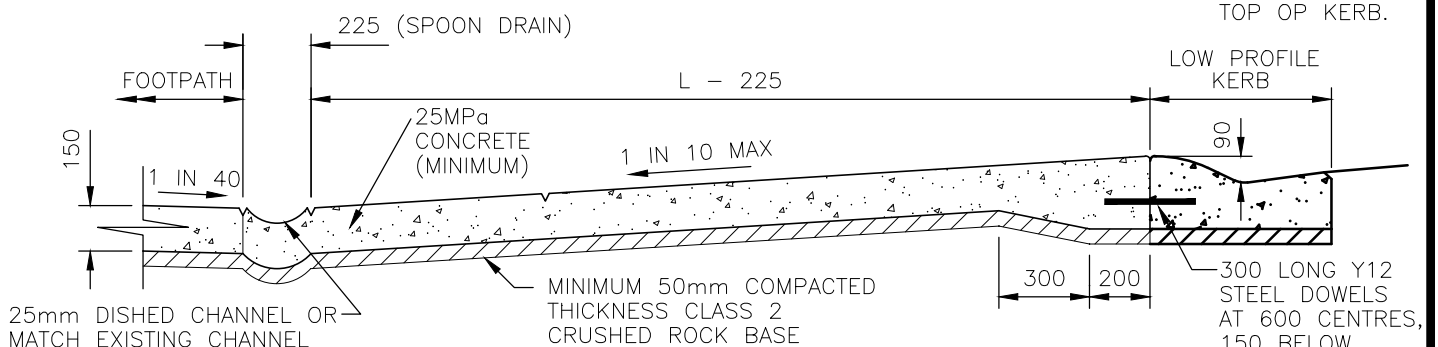

SECTION A-A REVERSE FALL CROSSING

SCALE 1:25

WHITEHORSE CITY COUNCIL

VEHICLE CROSSING

TYPE 1 - RESIDENTIAL STREETS

(MOUNTABLE KERB AND CHANNEL AND NATURE STRIP > OR = 3m)

AMENDED 08/23

S101A

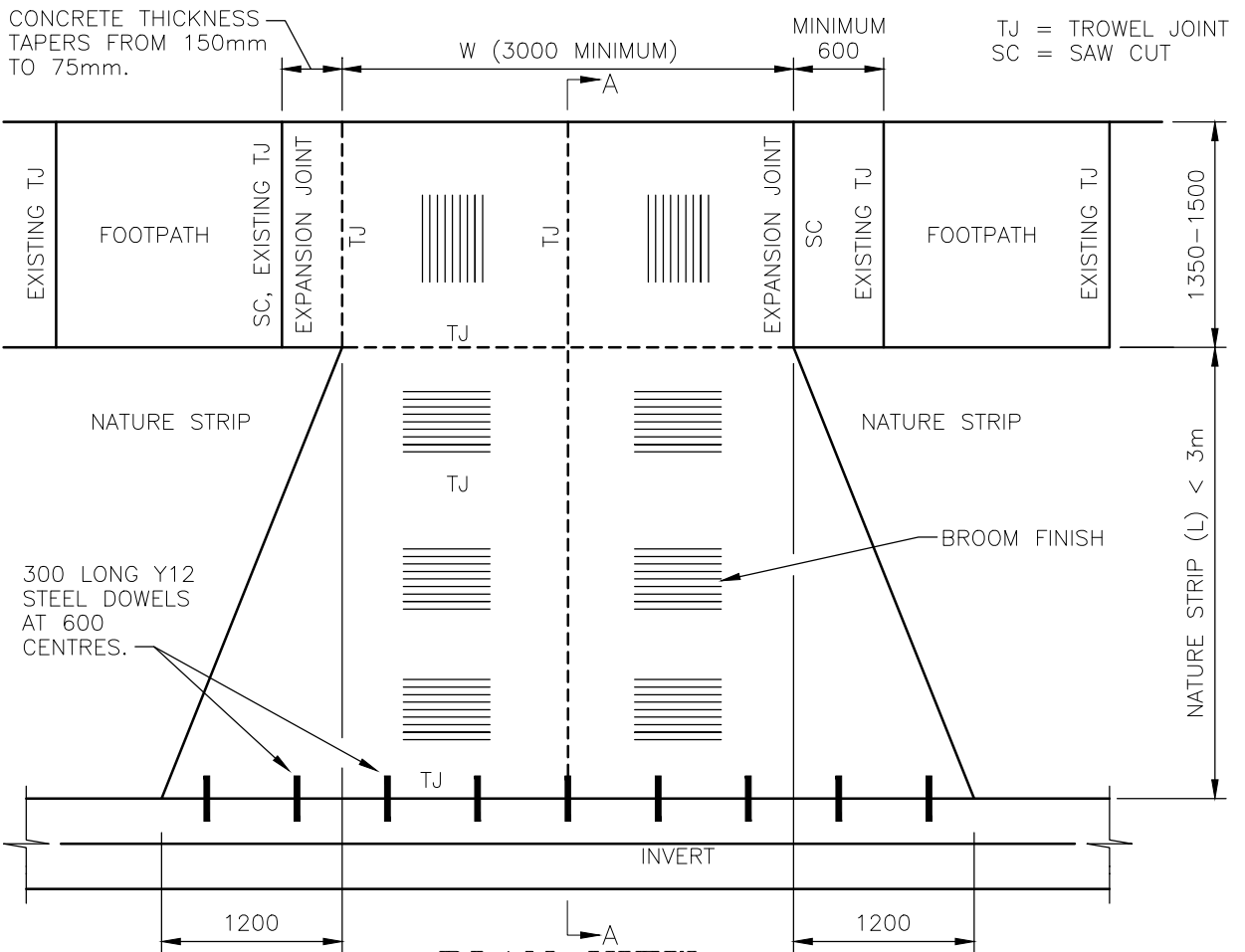

PLAN VIEW

SCALE 1:50

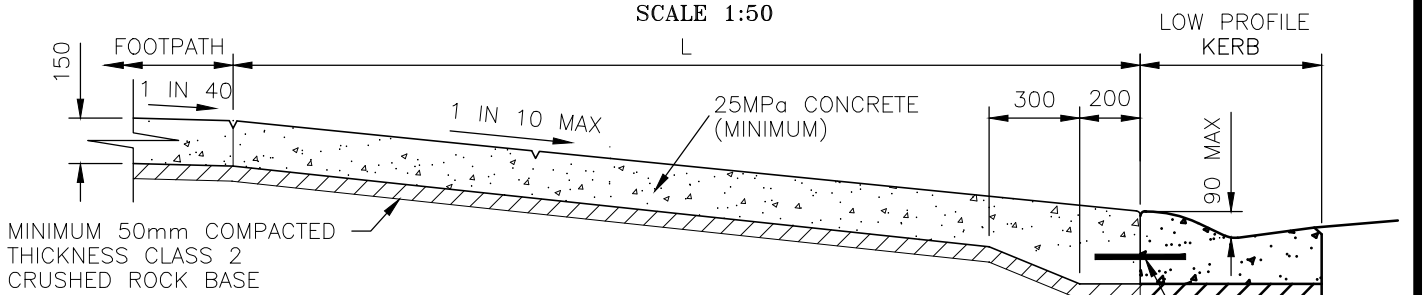

SECTION A-A NORMAL FALL CROSSING

SCALE 1:25

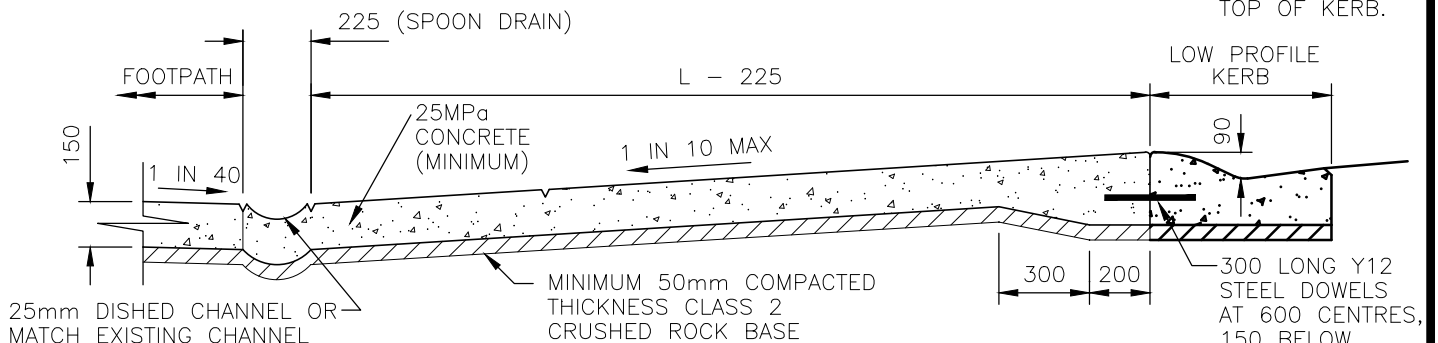

SECTION A-A REVERSE FALL CROSSING

SCALE 1:25

WHITEHORSE CITY COUNCIL

VEHICLE CROSSING

TYPE 1 - RESIDENTIAL STREETS

(MOUNTABLE KERB AND CHANNEL AND NATURE STRIP < 3m)

AMENDED 08/23

S101B

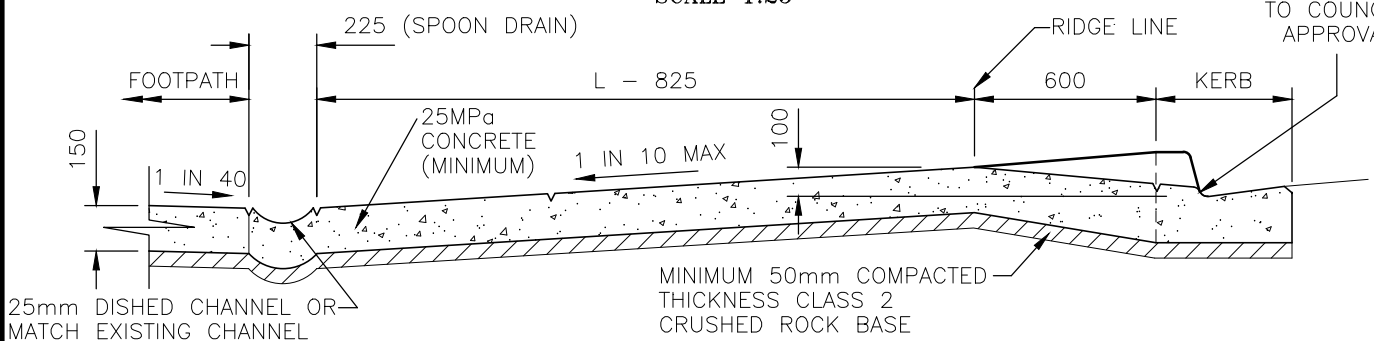
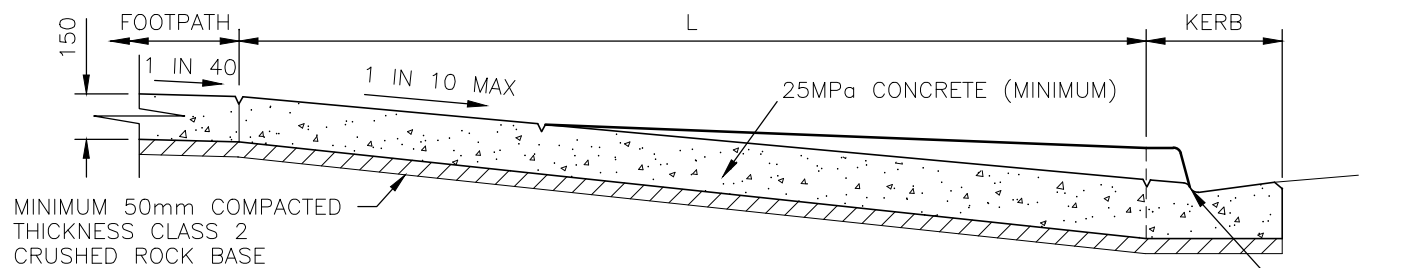
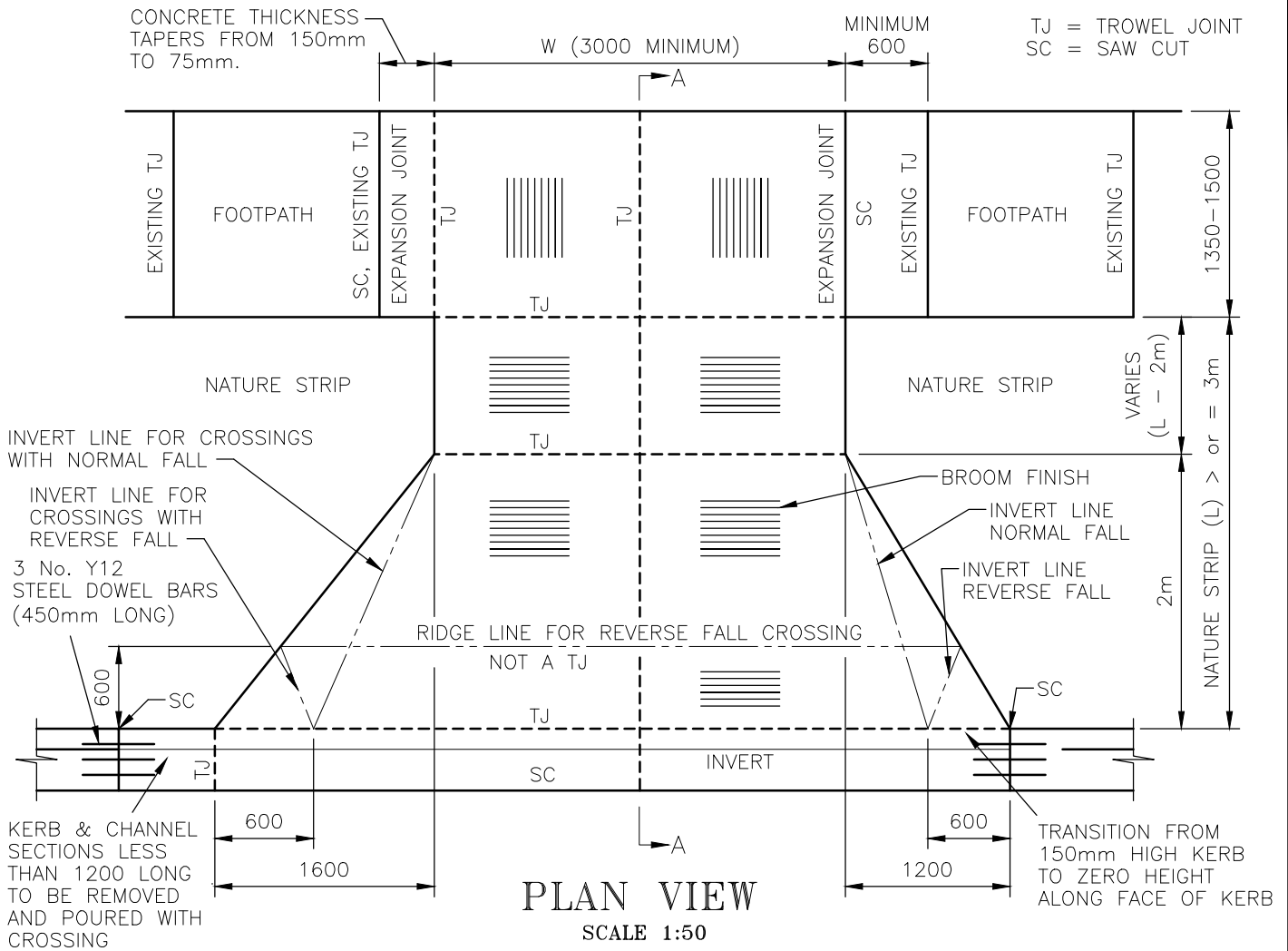

WHITEHORSE CITY COUNCIL

VEHICLE CROSSING TYPE 1 - MAJOR ROADS

(BARRIER KERB AND CHANNEL AND NATURE STRIP > OR = 3m)

AMENDED 08/23

S102A

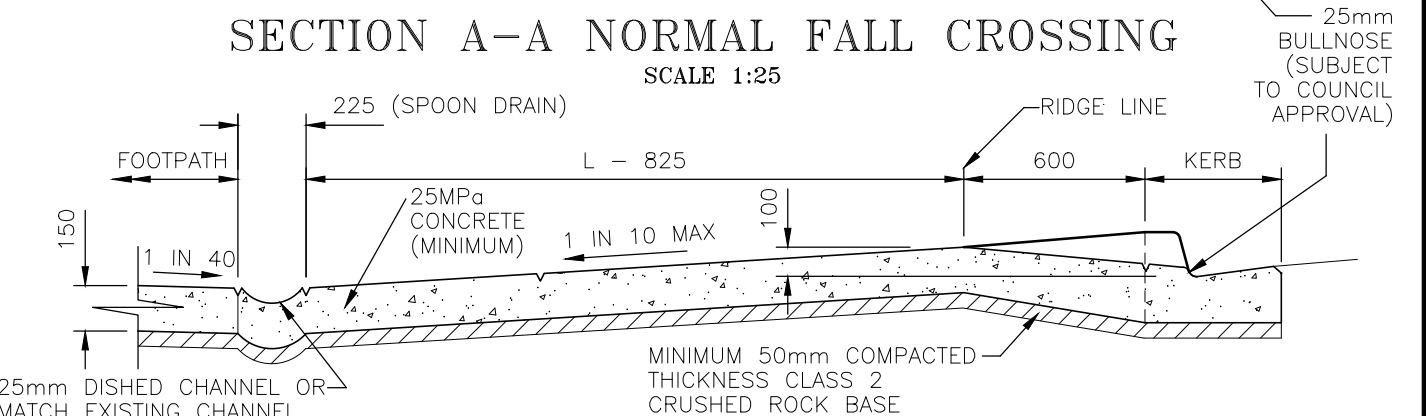
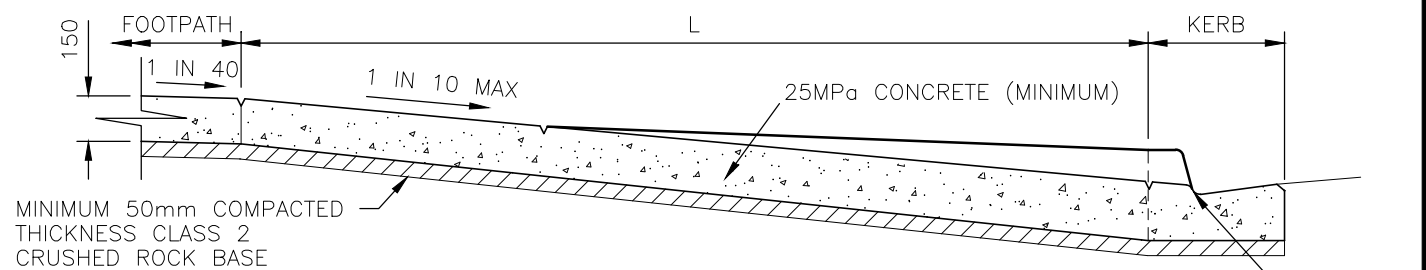
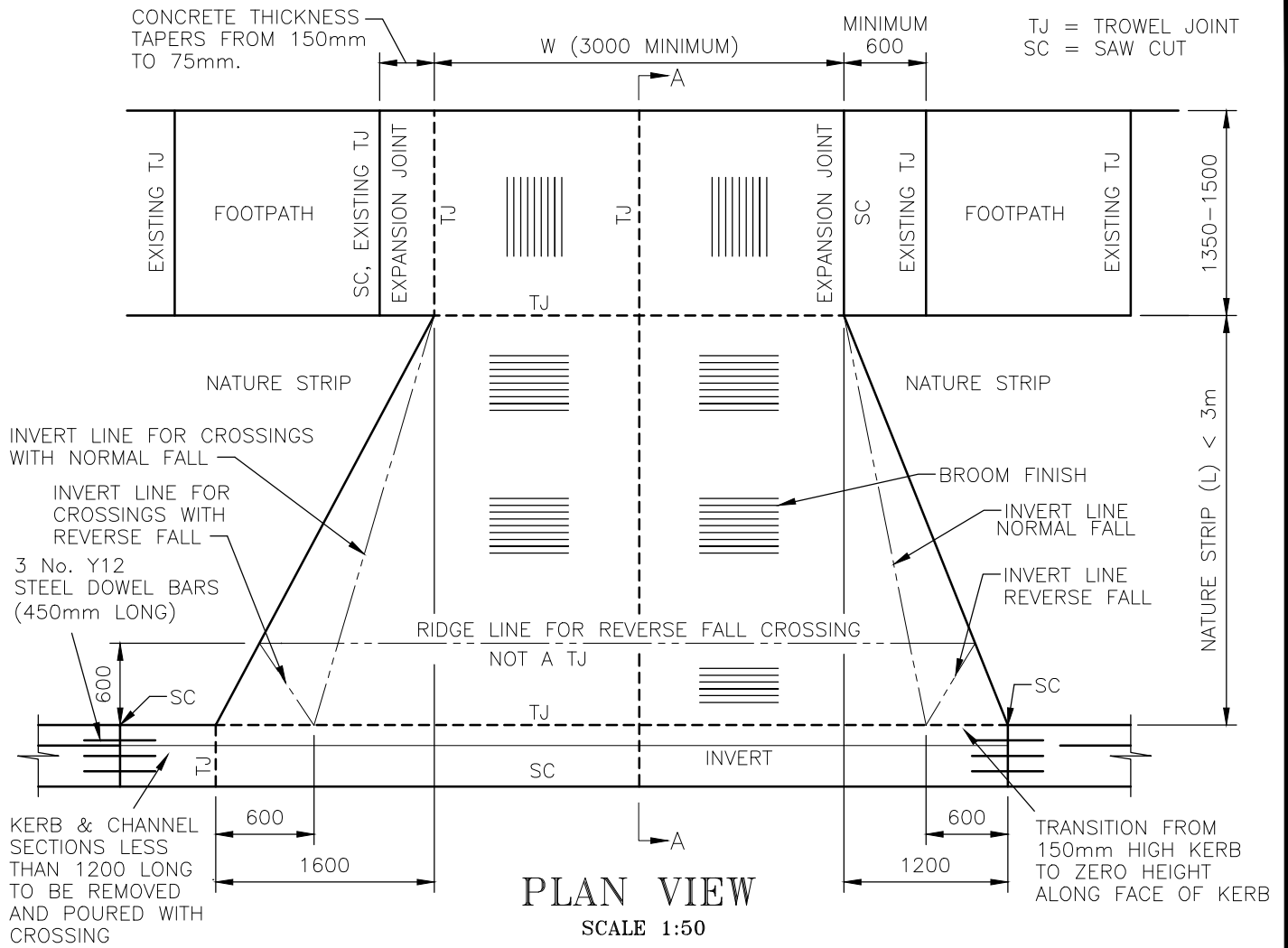

WHITEHORSE CITY COUNCIL

VEHICLE CROSSING TYPE 1 - MAJOR ROADS

(BARRIER KERB AND CHANNEL AND NATURE STRIP < 3m)

AMENDED 08/23

S102B

CONCRETE THICKNESS
TAPERS FROM 150mm
TO 75mm.

W (3000 MINIMUM)

MINIMUM
600

TP = TANGENT POINT
TJ = TROWEL JOINT
SC = SAW CUT

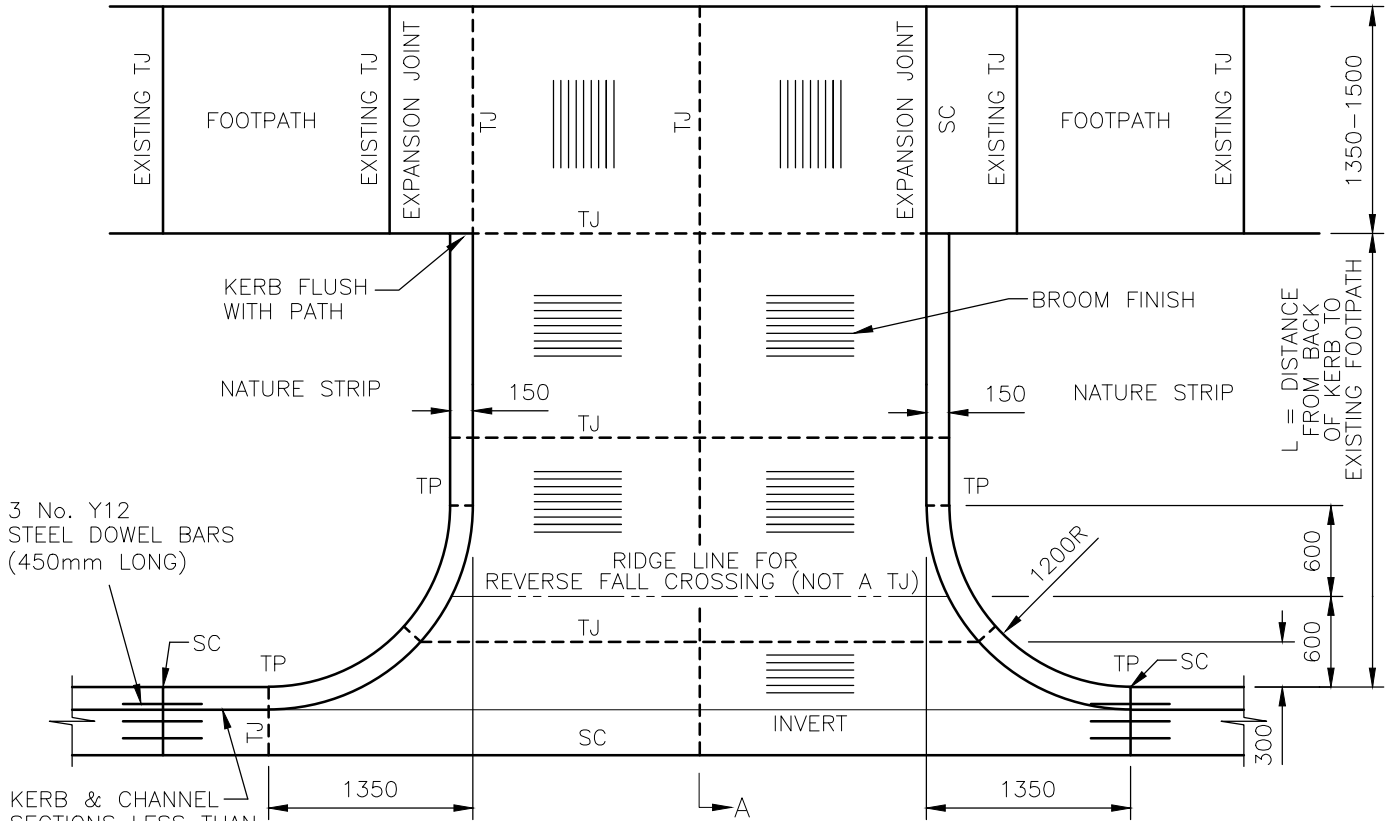

KERB & CHANNEL SECTIONS LESS THAN 1200 LONG TO BE REMOVED AND POURED WITH CROSSING

PLAN VIEW

SCALE 1:50

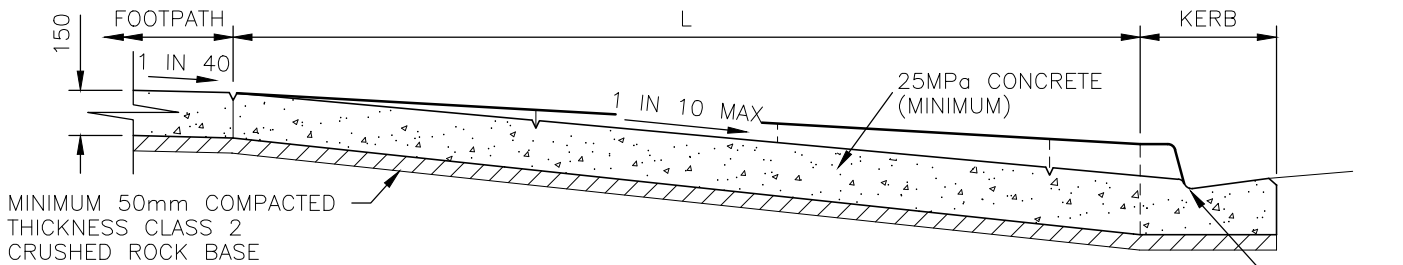

SECTION A-A NORMAL FALL CROSSING

SCALE 1:25

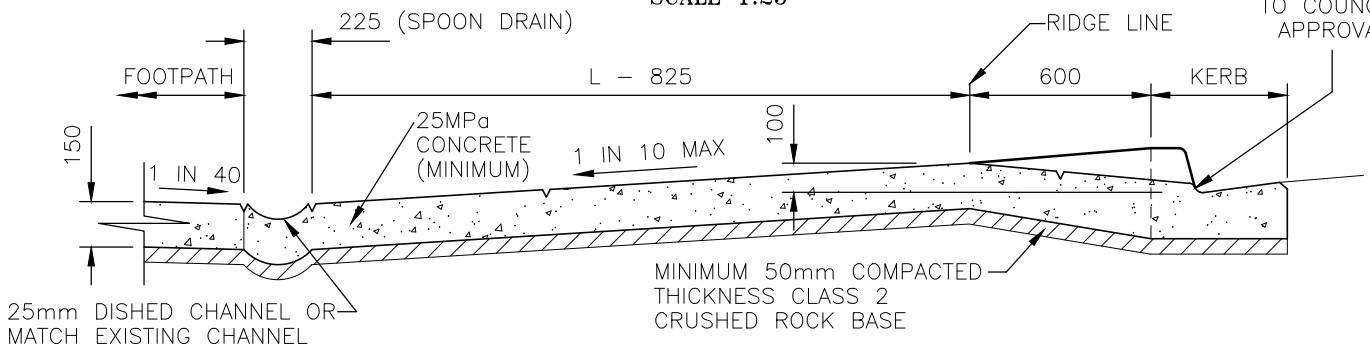

SECTION A-A REVERSE FALL CROSSING

SCALE 1:25

WHITEHORSE CITY COUNCIL

VEHICLE CROSSING

TYPE 2 - RESIDENTIAL STREETS

(ONLY TO BE USED WHEN EXTENDING AN EXISTING TYPE 2 CROSSING)

AMENDED 08/23

S103A

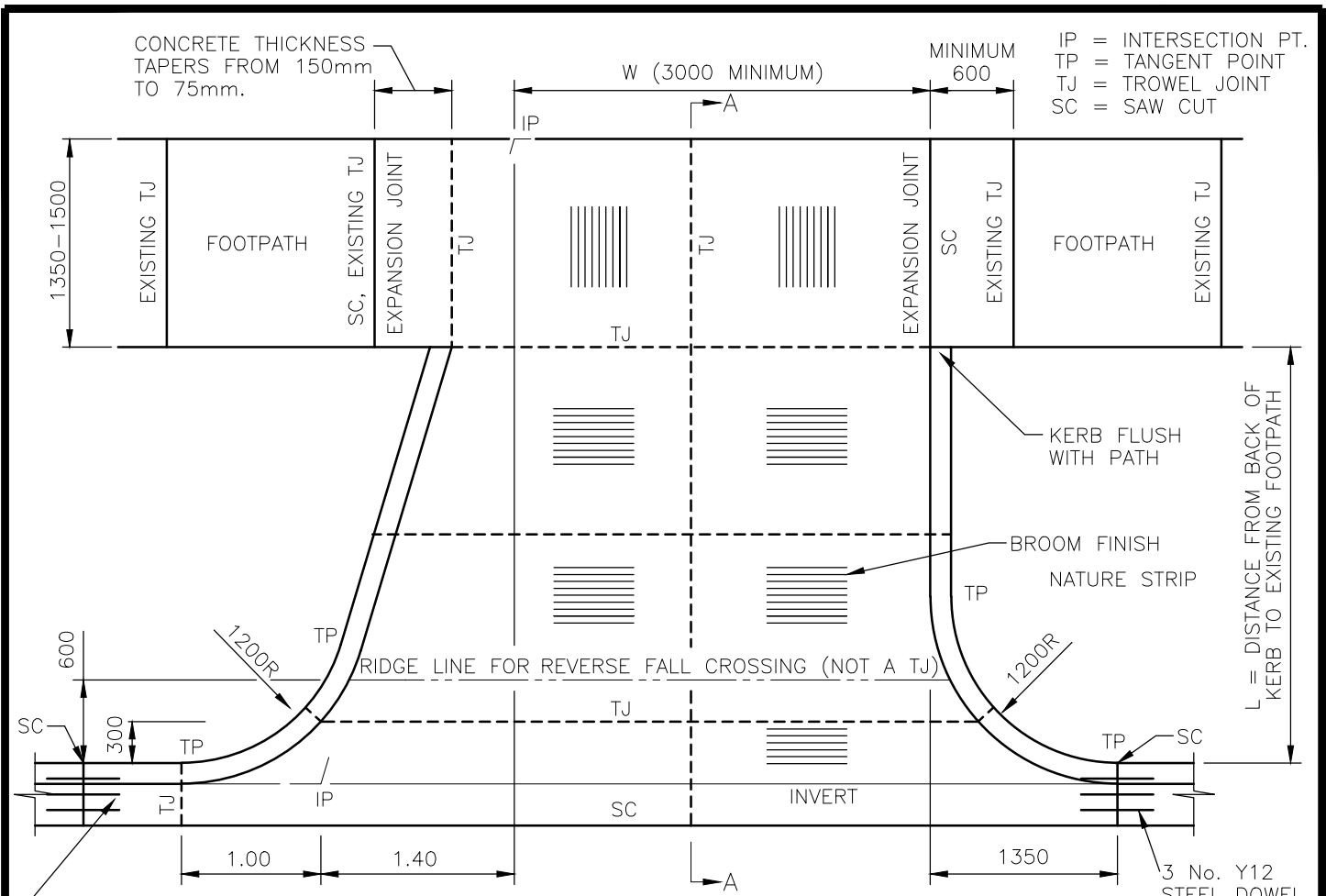

PLAN VIEW
 SCALE 1:50

KERB & CHANNEL SECTIONS LESS THAN 1200 LONG TO BE REMOVED AND POURED WITH CROSSING

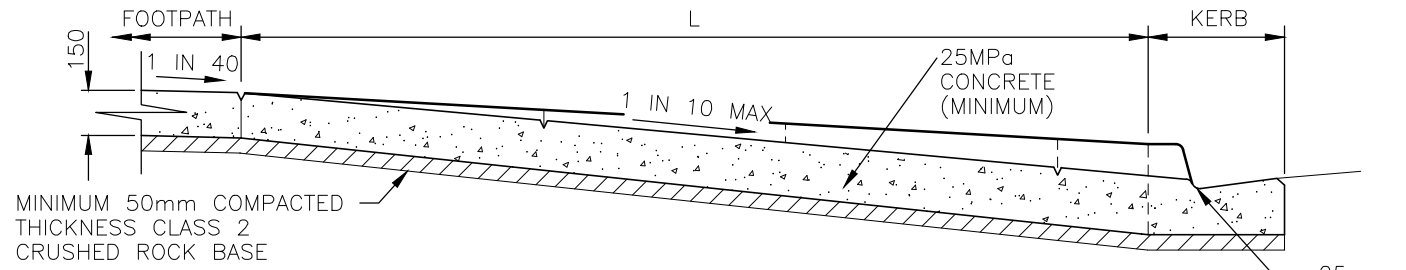

SECTION A-A NORMAL FALL CROSSING
 SCALE 1:25

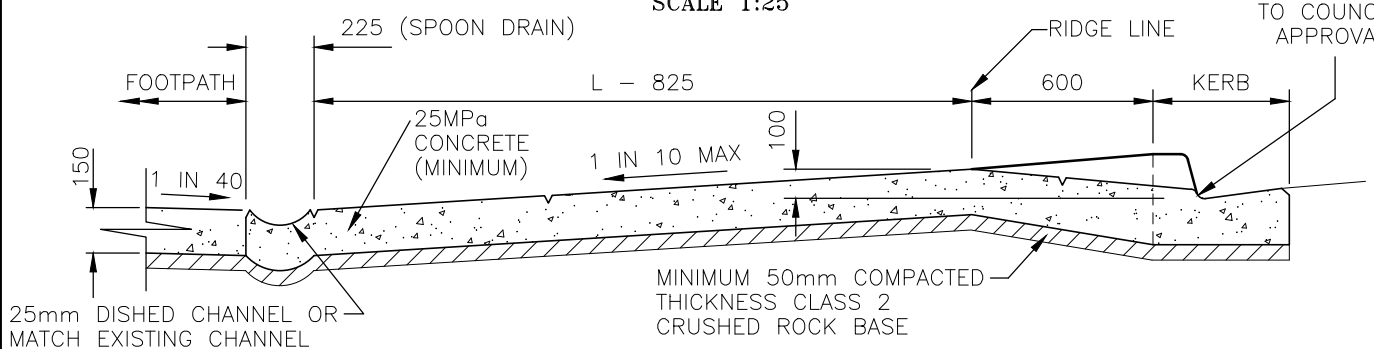

SECTION A-A REVERSE FALL CROSSING
 SCALE 1:25

WHITEHORSE CITY COUNCIL

**VEHICLE CROSSING
 TYPE 2 - MAJOR ROADS**

(ONLY TO BE USED WHEN EXTENDING AN EXISTING TYPE 2 CROSSING)

AMENDED 08/23

S104A

VEHICLE CROSSING GENERAL SPECIFICATIONS FOR LOCAL ROADS

1. CONSENT TO UNDERTAKE WORKS IN THE ROAD RESERVE APPLICATION FORM

- 1.1. The Road Management Act requires that consent from the responsible road authority (Whitehorse City Council) is required before a vehicle crossing can be constructed on all local roads within the City of Whitehorse.
- 1.2. Consent will not be given unless an application form has been lodged and approved by Council. This process is in place to ensure that the proposed location of the crossing does not conflict with Council and other authority's assets and to ensure that it is constructed to an appropriate standard. Council has a maximum of 20 working days to consider the application once all relevant documents have been received.
- 1.3. Under Council Local Law 2024 the property owner is responsible for ensuring that the Vehicle Crossing is properly constructed and is not a hazard to the general public. The conditions of the application form are to be disclosed to property owners to ensure that they are aware of their responsibilities.
- 1.4. An application fee and a deposit is payable in each case.
- 1.5. If the proposed crossing or any associated work is attached to an arterial road, Department of Transport and Planning (formerly VicRoads/Regional Roads Victoria) written consent will be required along with any other permits required by Department of Transport and Planning.

2. MINIMUM CONSTRUCTION STANDARDS

- 2.1. Residential vehicle crossings shall be constructed of unreinforced concrete, 150mm in depth, to the shape, grade and section as shown on the attached standard drawing and to the satisfaction of the Manager Engineering and Investment or their representative.
- 2.2. Commercial or Industrial vehicle crossings shall be constructed to a minimum thickness of 200mm with a 50mm compacted Class 2 crush concrete base and reinforced with SL82 mesh top and bottom having 50mm cover to the top and bottom layer of reinforcement
- 2.3. Every crossing shall be at least equal to the width of the gateway or driveway it serves and must be a minimum of 3.00m in width (measured between kerbs where applicable) unless otherwise stipulated on any planning permit. The maximum width of a residential crossing shall be 6.00m and for a commercial crossing 8.00m, unless permission from the Manager Engineering and Investment is obtained to exceed this width.
- 2.4. No crossing shall be constructed within 10.00m of any street or road intersection, measured from the kerb line intersection point.
- 2.5. Where two adjacent driveways are less than 1.20m apart, a double vehicle crossing shall be constructed.
- 2.6. Type 1 crossings shall be selected unless widening an existing Type 2 crossing or constructing a double crossing with the existing section being a Type 2 crossing, see Whitehorse City Council Standard Drawings for crossings types.
- 2.7. Install 3 No. Y12 steel Dowel Bars (450mm long) to connect proposed vehicle crossing to existing kerb and channel or as directed by the Manager Engineering and Investment or their representative.

3. INSPECTIONS

- 3.1. A minimum of three working days' notice shall be given as to when the works will be ready for inspection. Crossings will only be inspected between the hours of 9:30am and 1:30pm, Monday to Friday.
- 3.2. Crossings will not be inspected on Saturdays, Sundays or public holidays unless warranted by special circumstances. If special circumstances exist, a special inspection fee is to be pre-paid at least one week prior to the commencement of work. Approval to carry out works under special circumstances is subject to the availability of a Council Officer to supervise the works.
- 3.3. No concrete is to be poured until the base, formwork and reinforcement (if any) has been inspected and approved.

4. ALTERATIONS TO EXISTING SERVICES

- 4.1. Vehicle crossings shall be located to avoid interference with existing services including pits, poles, valves, etc. If such interference is unavoidable, the applicant shall be responsible for the cost of all necessary alterations and/or additions. The minimum clearance to poles shall be 1.00m.
- 4.2. Existing junction pits shall be lowered and appropriate size and type. For Junction Pits, concrete class D cast iron frame with concrete infill to AS3996:2019. For Grate Pits, Class D non slip bike safe grate. Cover and frame fitted and the top of the cover being set flush with the finished surface of the new crossing.

WHITEHORSE CITY COUNCIL

SPECIFICATION FOR CONSTRUCTION

VEHICLE CROSSINGS

AMENDED 08/24

S105

- 4.3. Permission may be granted to modify or delete an existing side entry pit provided that an additional pit(s) is constructed at the applicant's expense, as directed by the Manager Engineering and Investment or their representative. A written application is to be submitted to the Manager Engineering and Investment for approval. A crossing permit will be invalidated if approval has not been obtained prior to a permit being issued.
- 4.4. No crossing shall be constructed within **4.0m** of an existing street tree. Council reserves the right to refuse the removal of a tree, or direct that any street tree be removed and replaced by Council staff, at the applicant's expense, as deemed necessary. If the location of the proposed crossing conflicts with an existing street tree or the required clearances cannot be met, a written application for its removal, or exemption from the specified clearance, is to be submitted to the Council's Parks and Natural Environment Department for approval. The Manager Parks and Natural Environment shall determine the fee payable. Approval to construct a vehicle crossing will be invalidated if approval has not been obtained prior to a permit being issued.
- 4.5. If the construction of a crossing necessitates the alteration of any public service or utility, such alterations are to be arranged with the respective authority at the applicant's expense prior to the commencement of construction of the crossing. House drains, agricultural drains, conduits, etc., damaged during construction of the crossing shall be repaired or reconstructed to the satisfaction of the Manager Engineering and Investment or their representative at the applicant's expense.

5. EXISTING CONCRETE

- 5.1. Existing concrete kerb and channel shall be removed to the nearest whole bay and repoured as an integral part of the crossing. The kerb and channel may be saw cut if the residual bay is a minimum 1.20m long
- 5.2. Where there is existing 75mm thick concrete footpath in the line of the works, this is to be removed and replaced with 150mm thick concrete across the crossing width and one bay either side of the proposed crossing.
- 5.3. Where an unused crossing exists at a different location to the proposed crossing, the existing crossing, including the concrete channel, shall be removed completely and concrete kerb and channel reinstated. It may be acceptable for the footpath to remain provided that it is in a good condition and is saw cut along the front of path. Nature strips adjoining the reinstatement are to be made good to correct levels with topsoil and seeded. This work shall be carried out concurrently with the crossing construction.

6. PREPARATION

- 6.1. The ground is to be excavated and neatly trimmed to give a clear depth of 200mm below the finished level of the concrete for residential crossings and 250mm below for Commercial or Industrial crossings. All excavated material shall be removed from the road reserve at the time of construction.
- 6.2. In cases where over-excavation has occurred or where unstable ground conditions are encountered, class 2 crushed concrete must be used to bring the over-excavation up to the level of the boxing. Unstable ground must be removed and replaced with class 2 crushed concrete and must be compacted in 150mm layers using a vibrating plate.
- 6.3. The permit holder shall spread a layer of class 2 crushed concrete to give a finished base depth of 50mm after compaction with a vibrating plate. Crushed concrete is to be wetted prior to compaction.

7. MATERIAL STORAGE

- 7.1. Construction materials shall not be placed or dumped on the road pavement, nature-strip, kerb and channel or footpath. Hand mixing of concrete or mortar on the road pavement or footpath is prohibited.

8. REINFORCEMENT

- 8.1. Commercial crossings shall be reinforced with SL82 mesh. The reinforcement shall be set up on bar chairs to provide 40mm cover from the top surface of the concrete. Industrial crossings shall be reinforced with SL92 mesh (2 layers).

9. CONCRETE

- 9.1. Pre-mixed concrete shall consist of a mixture of 20mm maximum size aggregate, washed sand and Portland cement. Sufficient water shall be added at the batch plant to provide a slump of not less than 40mm and not more than 75mm at the time of pouring. No water is to be added to the concrete after it leaves the batch plant. The compressive strength of the concrete shall not be less than 25Mpa at 28 days and 32Mpa at 28 days for Commercial and Industrial crossings. Every batch of concrete transported in a truck agitator shall be delivered and placed before rapid stiffening of the concrete develops, but in no case shall the time exceed 1.5 hours after the introduction of water to the mixture.
- 9.2. Colour for selected bluestone pitcher kerb and channel lined streets to be determined by Engineering and Investment or as advised by their representative.

WHITEHORSE CITY COUNCIL

SPECIFICATION FOR CONSTRUCTION

VEHICLE CROSSINGS

AMENDED 08/24

S105

10. JOINTS

- 10.1. Expansion joints shall be located at the nearest joint in the footpath on either side of the crossing and at the property boundary where the crossing abuts a concrete driveway. Expansion jointing material shall extend the full width and depth of the paving.
- 10.2. Contraction joints shall be formed in the crossing in accordance with the standard drawing or as directed. The jointing pattern will be such as to form the crossing into bays of not more than 3 square metres. Joints shall be formed by creating a plane of weakness through the concrete after it has taken its initial set and should be defined in the finished concrete surface by means of an approved grooving tool.

11. FINISH

- 11.1. The surface of the concrete shall be brought to a smooth, even mortar finish, which must be applied to the concrete within half an hour after placing or be brought to the surface by the use of a perforated roller or wood float. The mortar finish shall consist of one part cement, one part sand and one part screened bluestone dust. The use of driers is not permitted. The final surface is to be obtained by lightly drawing a hair broom over the whole of the finished surface to provide an even, non-skid finish. Concrete kerb and channel shall be finished with a steel trowel to a smooth surface. On no account will consideration be given to using concrete abrasives, additives or any similar products with a view to the mortar finish being applied after the half hour has elapsed.

12. CURING

- 12.1. No vehicle shall use a newly poured crossing for at least ninety six (96) hours/ four days from the time of pouring to allow the concrete to attain a satisfactory strength. An approved curing compound shall be applied between the months of December and March inclusive or when the forecast top temperature exceeds 25 degrees Celsius.

13. BARRICADES AND LIGHTING

- 13.1. The applicant shall supply and erect any barriers, signs, lights, etc. to ensure the safety of all traffic, both vehicular and pedestrian and to protect the works from damage, in accordance with the Department of Transport and Planning Roadworks Signing Code of Practice, Australian Standards AS1742-3, Road Management Act 2004 Worksite Safety - Traffic Management Code of Practice.

14. CLEANING UP

- 14.1. Upon completion of the work the Applicant shall remove all surplus material from the site and resurface the nature strip with a minimum of 100mm topsoil and seed or as directed by Council officers. The Applicant shall reinstate any damaged road pavement along the road/ crossing interface to the satisfaction of the Manager Engineering and Investment or their representative.

15. CROSSING CONSTRUCTED WITHOUT A PERMIT

- 15.1. If a crossing is constructed without a permit or consent, without Council supervision or has not been properly constructed to Council standards, the Council may require the property owner or applicant to reconstruct the crossing or completely remove the crossing and reinstate the footpath, kerb and channel, or any other assets in accordance with Community Local Law 2024, Road Management Act 2004 and relevant Regulations and Codes.

16. CROSSINGS FOR ARTERIAL ROADS

- 16.1. Consent and construction standards to undertake works must be obtained from relevant managing Road Authority - Please refer to council website to determine if location of your works are on an Arterial Road and for the appropriate process to follow:
<https://www.whitehorse.vic.gov.au/roads-footpaths-and-vehicle-crossings/vehicle-crossing-or-driveway/step-1-location-vehicle-crossing-works>

WHITEHORSE CITY COUNCIL

SPECIFICATION FOR CONSTRUCTION

VEHICLE CROSSINGS

AMENDED 08/24

S105

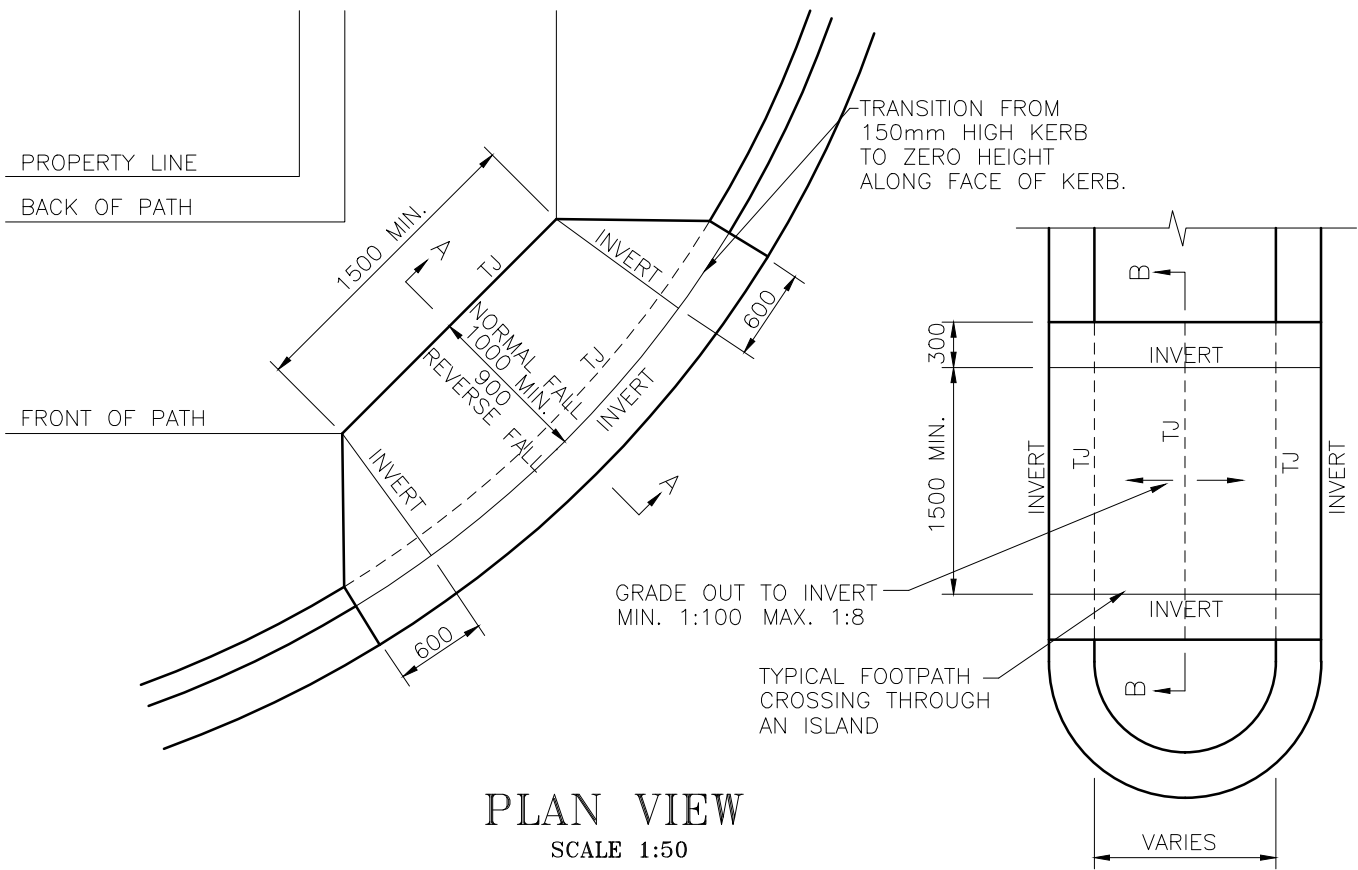

PLAN VIEW
SCALE 1:50

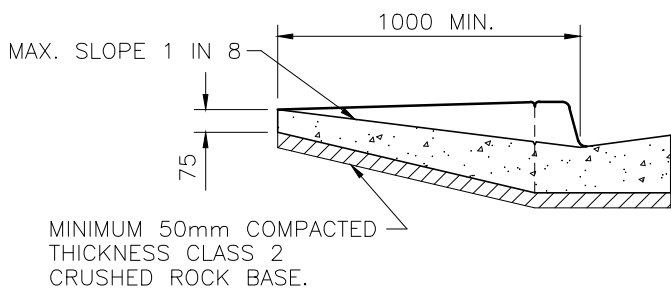

SECTION A-A
NORMAL FALL CROSSING
SCALE 1:25

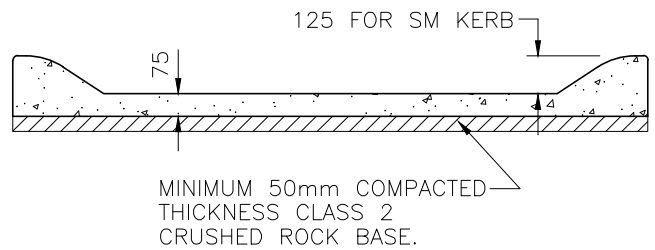

SECTION B-B
SCALE 1:25

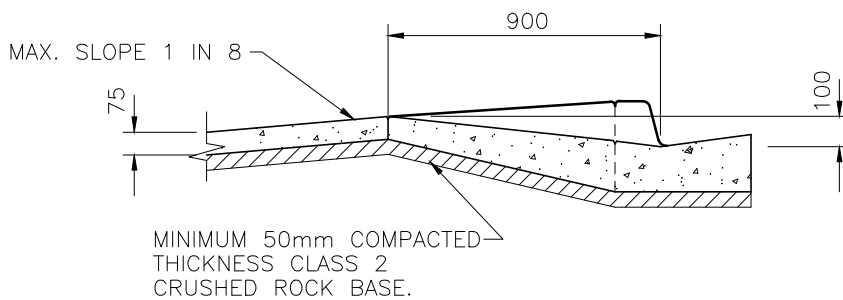

SECTION A-A
REVERSE FALL CROSSING
SCALE 1:25

WHITEHORSE CITY COUNCIL

FOOTPATH CROSSINGS

AMENDED 08/23

S106

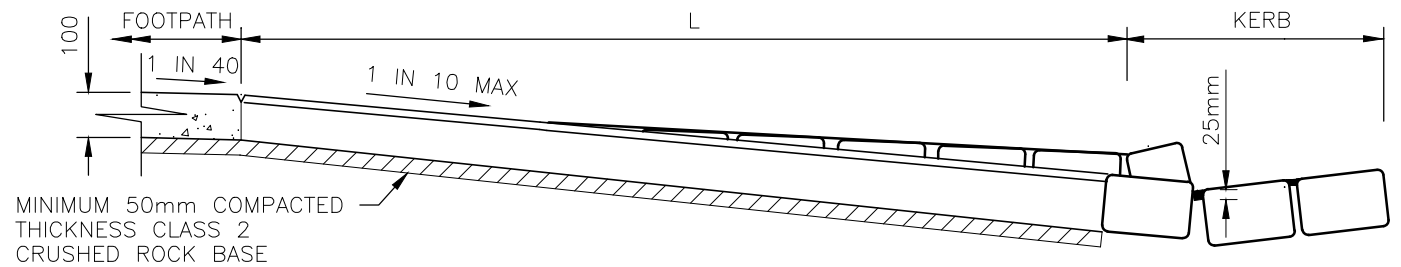
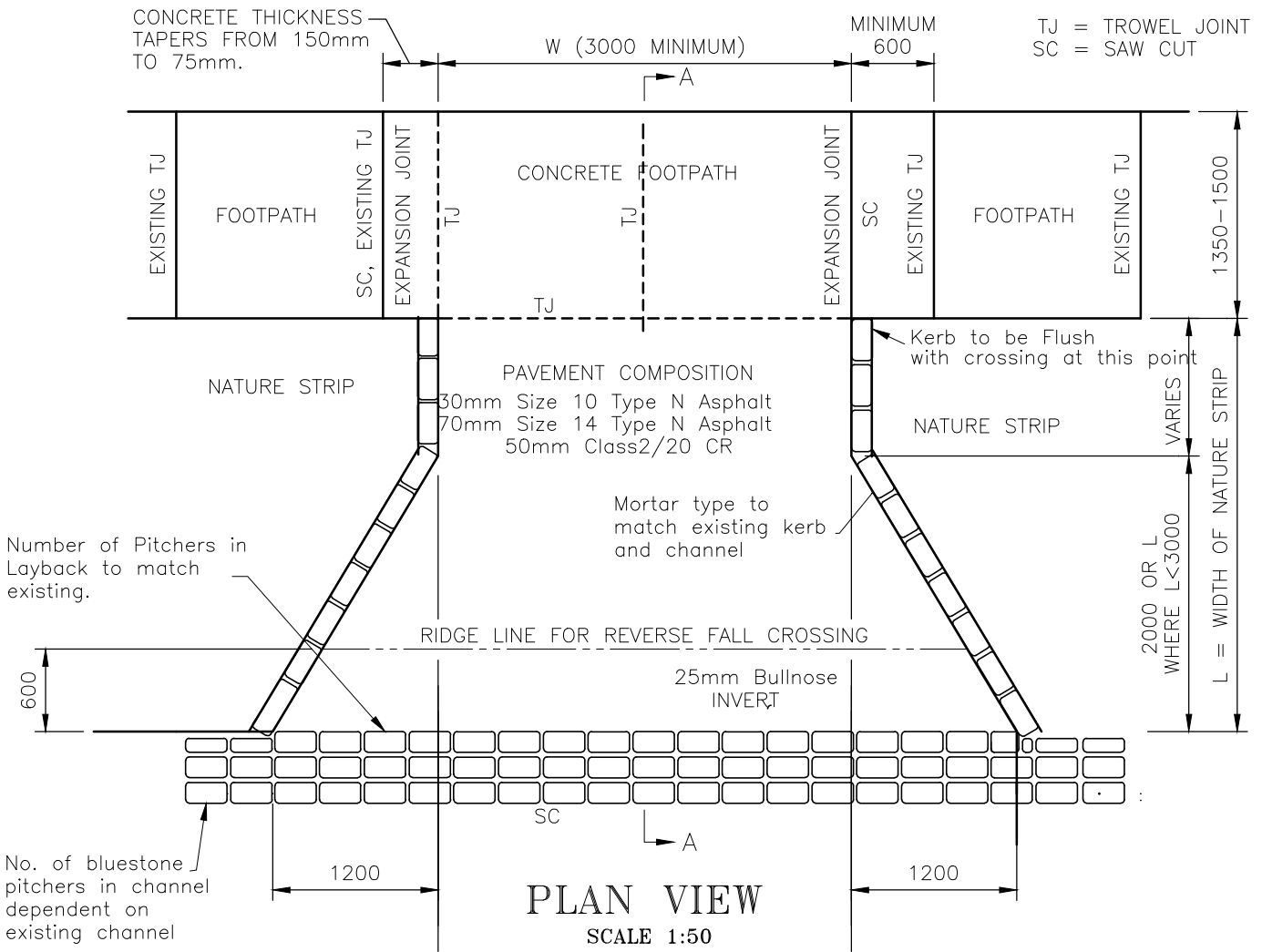

SECTION A-A NORMAL FALL CROSSING

SCALE 1:25

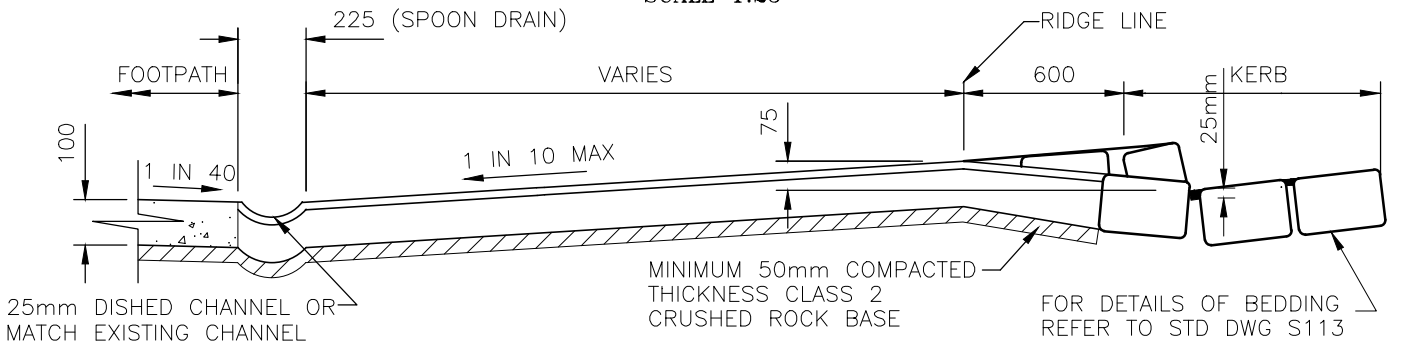

SECTION A-A REVERSE FALL CROSSING

SCALE 1:25

WHITEHORSE CITY COUNCIL

VEHICLE CROSSING

TYPE 1 - RESIDENTIAL STREETS

(FOR USE WITH PITCHER KERB AND CHANNEL)

AMENDED 08/23

S107